

Mixer

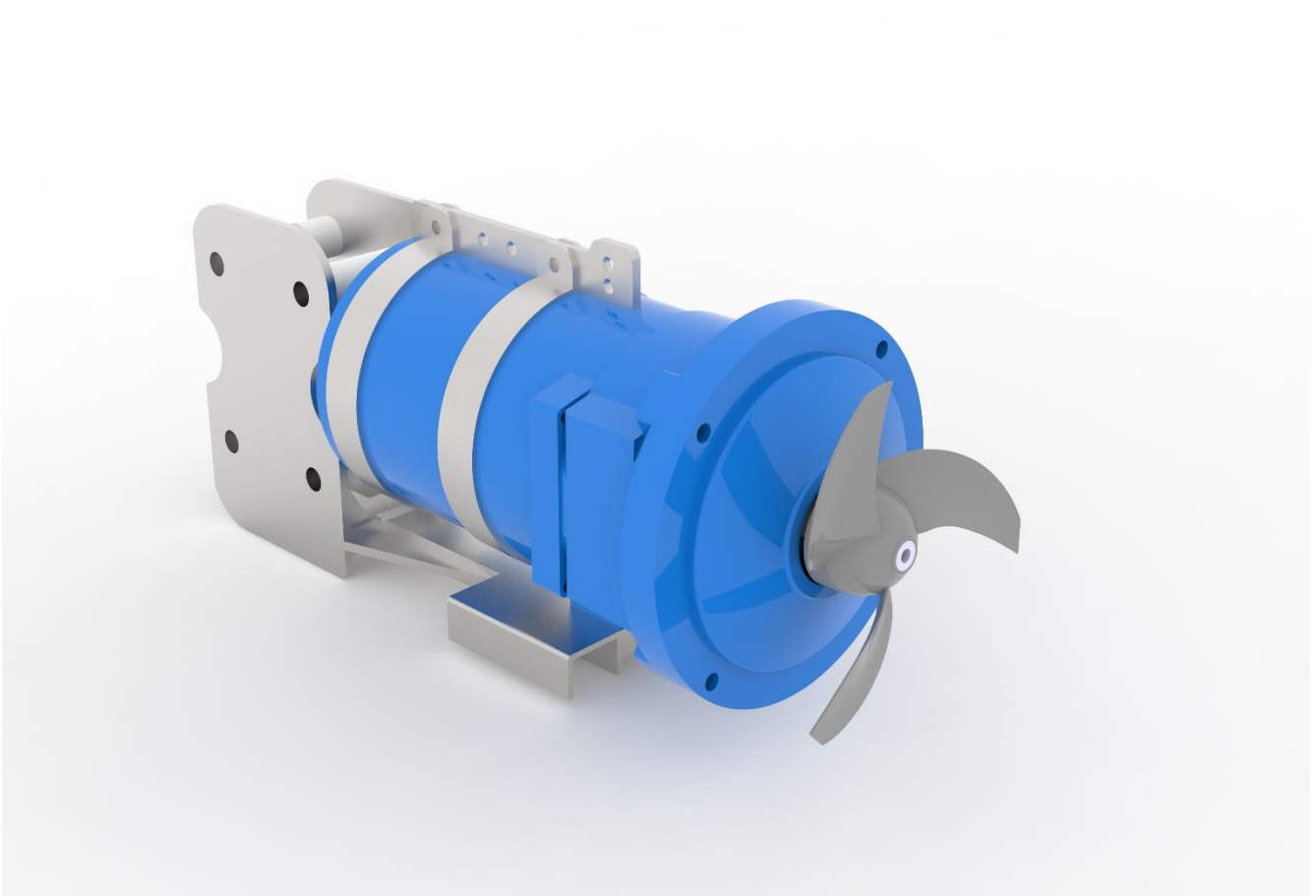

Berkeh pump energy efficient submersible mixers are suitable for a wide range of applications in industry and municipal treatment plants. They provide the right solution to match mixing tasks for agitating, blending, mixing, dissolving and suspension of solids in industry and municipal treatment plants.

Main benefits

- Compact, water pressure-tight design
- Reduced energy costs
- Shorter mixing times
- Minimal risk of motor overloading
- Easy installation
- Small space requirements

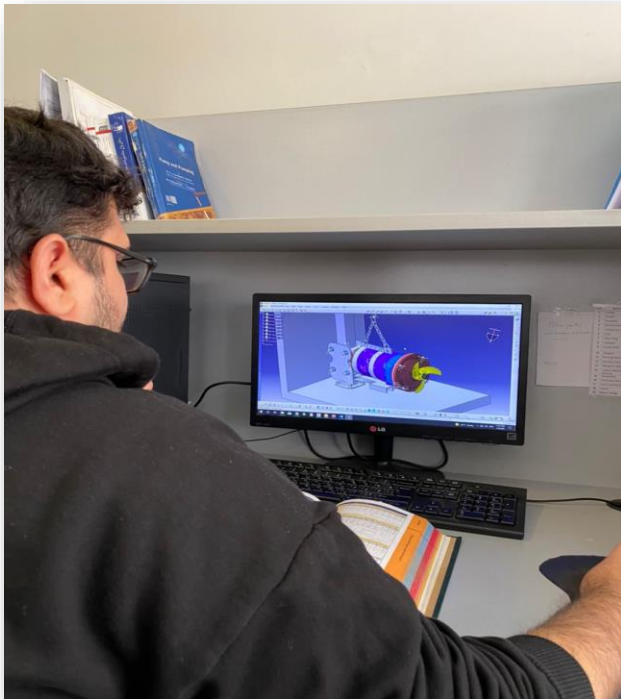

Berkeh Pumps Co.

Tel: 021-56546894-7

Fax:021-56546894-7

Tehran Industrial Zone , Qom old-

Road,Tehran,Iran

www.berkeh.com

Info@berkeh.com

Main applications

- Mixing and stirring applications in sewage treatment plants and industrial areas
- Homogenization of highly-concentrated sludge and slurries
- Hazardous locations ATEX (Ex II 2G Ex h db IIB T4 Gb), FM and CSA available as an option

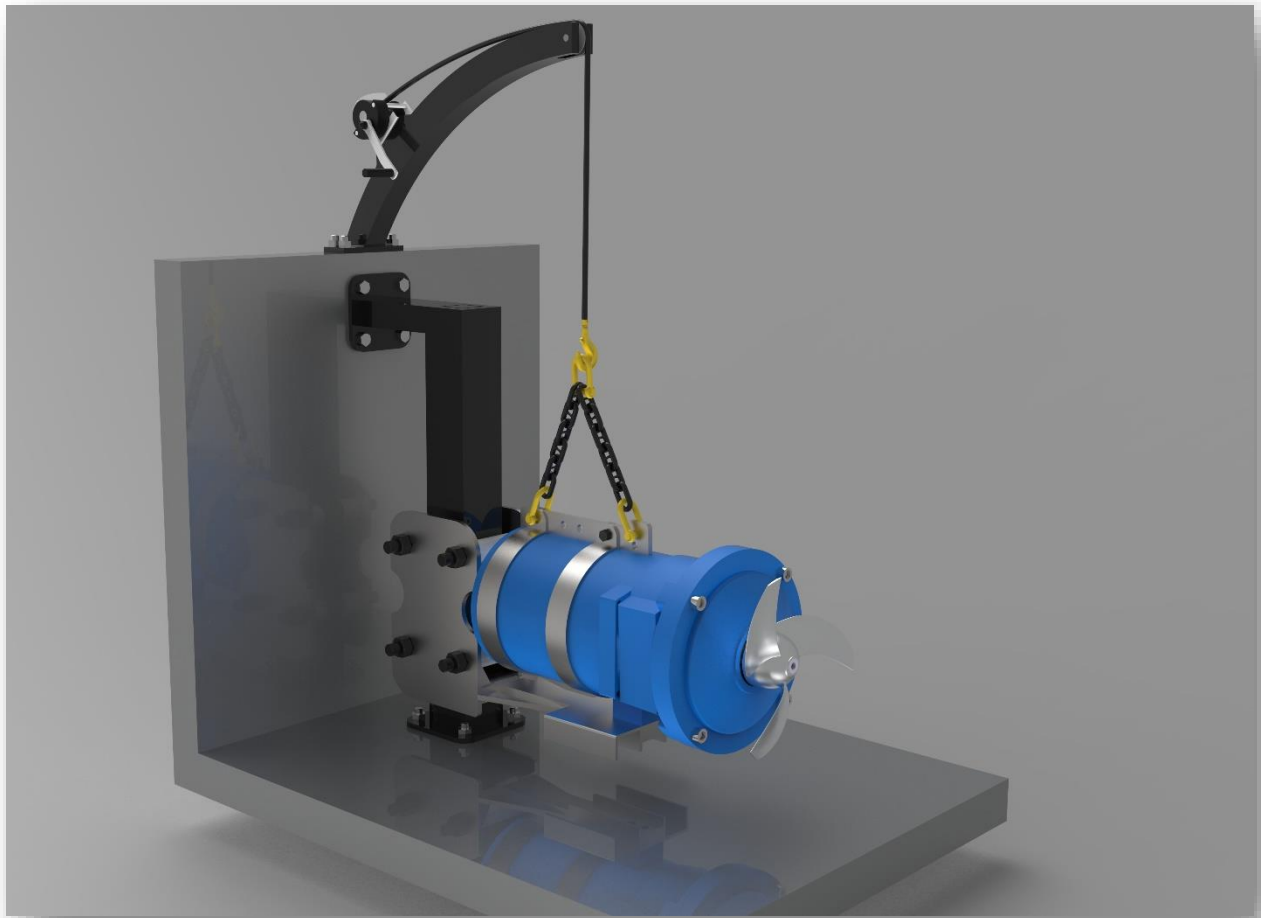

Berkeh Pumps Co.

Tel: 021-56546894-7

Fax:021-56546894-7

Tehran Industrial Zone , Qom old-

Road,Tehran,Iran

www.berkeh.com

Info@berkeh.com

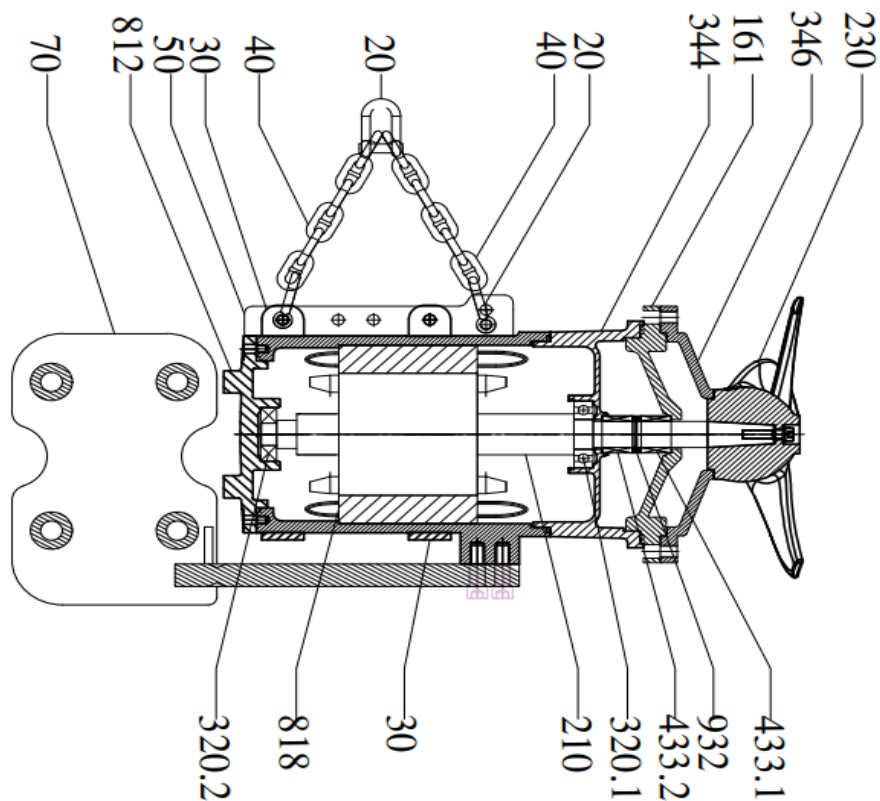

1	230	Impeller
2	346	Impeller Adaptor
3	161	Pump Cover
4	344	Adaptor
5	20	Bow shackle
6	40	Chain
7	30	Clamp
8	50	Hook
9	812	Motor Cover
10	70	Mast bracket and suspension
11	433.1	Mechanical seal
12	932	Snap Ring
13	433.2	Mechanical seal
14	320.1	Deep groove ball bearing
15	210	Rotor
16	818	stator
17	320.2	Deep groove ball bearing

Berkeh Pumps Co.

Tel: 021-56546894-7

Fax:021-56546894-7

Tehran Industrial Zone , Qom old-

Road,Tehran,Iran

www.berkeh.com

Info@berkeh.com

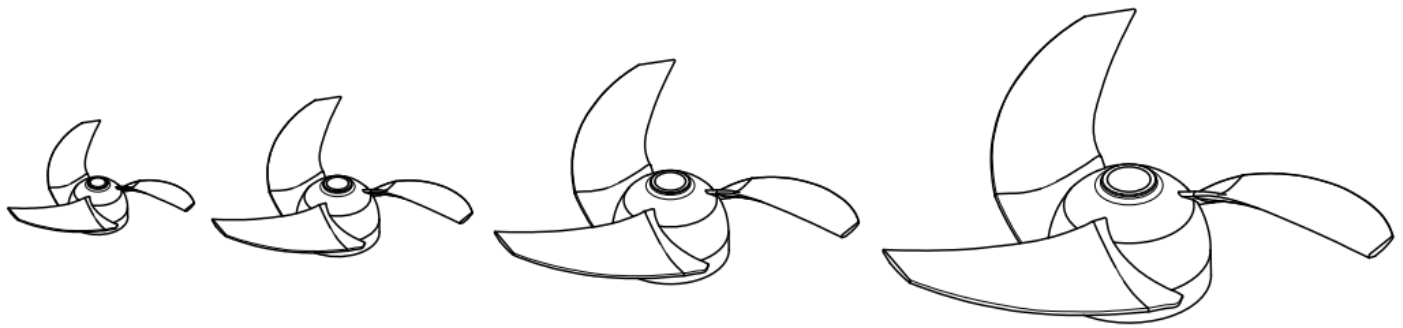

Impeller size(mm)	200	300	400	600
Speed(RPM)	1500	1000	750	500
Power(KW)	1~3	3~5.5	5.5~7.5	11~15

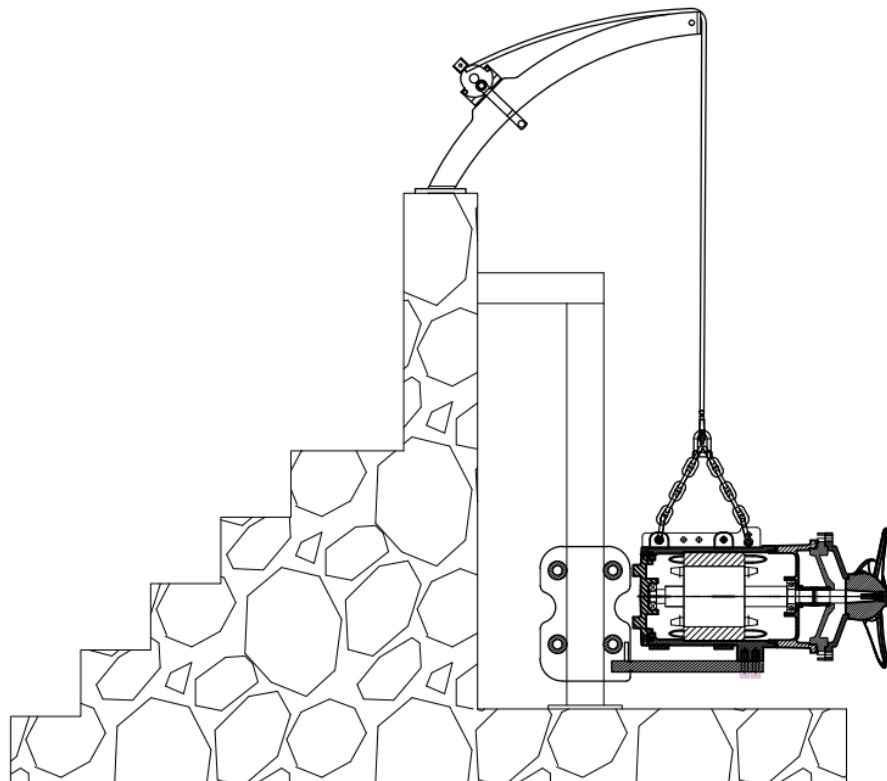

Berkeh Pumps Co.

Tel: 021-56546894-7

Fax:021-56546894-7

Tehran Industrial Zone , Qom old-

Road,Tehran,Iran

www.berkeh.com

Info@berkeh.com